



**Oregon Department of Justice**  
Ellen F. Rosenblum, Attorney General

**2019 Joint Committee on Ways & Means  
Public Safety Subcommittee Presentation – Phase 2  
April 24-25, 2019**



# Mission & Values

**To serve state government and to support safe and healthy communities throughout Oregon by providing essential justice services.**

We are dedicated to:

- Providing ethical, independent and high quality legal services to state government;
- Safeguarding consumers from fraud and unfair business practices;
- Fighting crime and helping crime victims;
- Advocating for vulnerable children;
- Supporting families through the collection of child support;
- Enforcing environmental protections;
- Defending the civil rights of all Oregonians; and
- Pursuing justice and upholding the rule of law.



# Organization

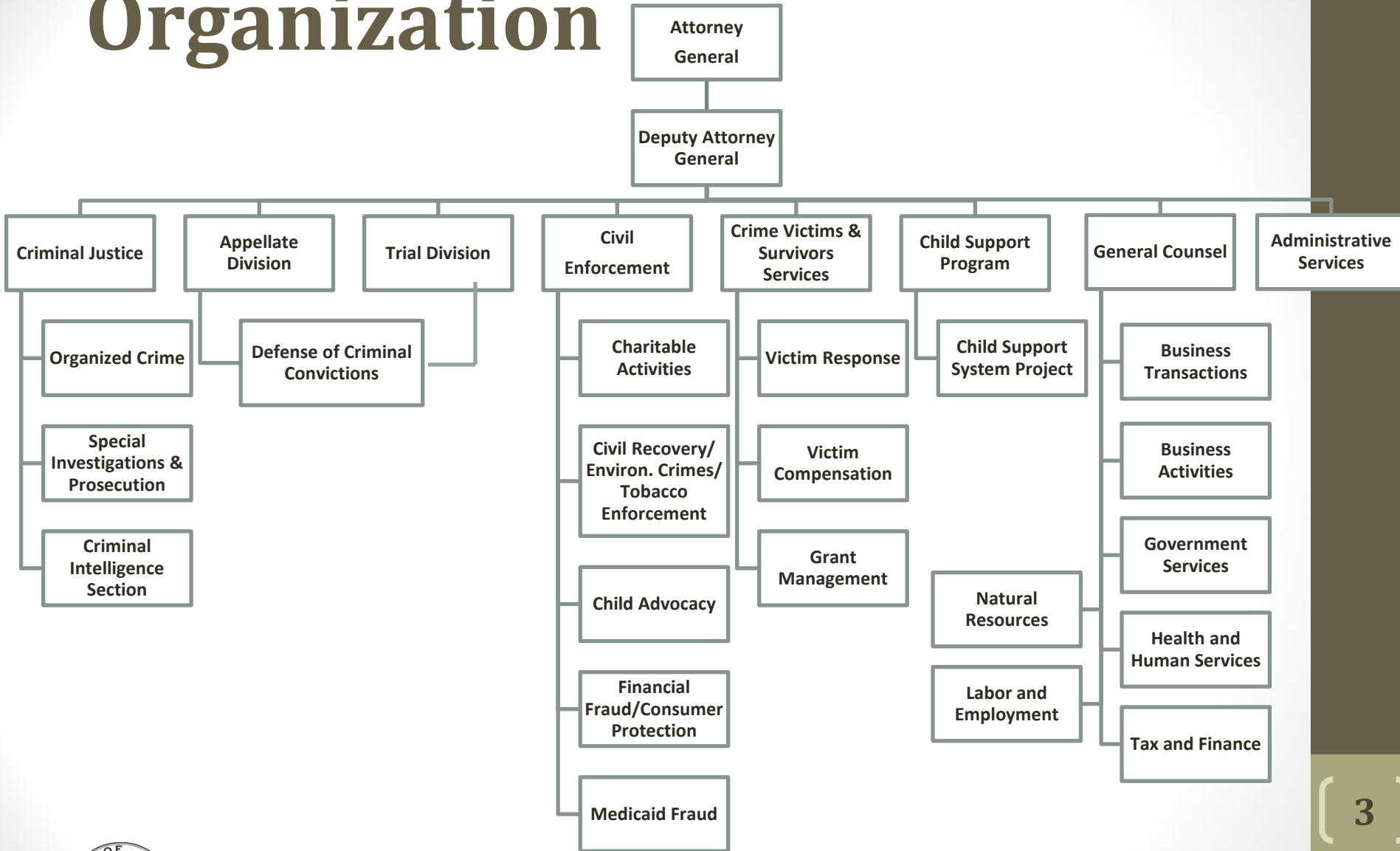

# Critical Priorities

- Ensuring the ongoing stability of our operating structure.
- Protecting the interests of Oregon children through the legislatively initiated Child Advocacy expansion.
- Supporting Criminal Justice efforts to resolve complex criminal cases.
- Supporting crime victims and survivors.
- Advocating for Oregon families.
- Providing responsive, high quality legal services to state agencies.
- Maximizing external funding to advance State of Oregon objectives.
- Protecting Oregon Citizens.





**Oregon Department of Justice**  
Ellen F. Rosenblum, Attorney General

# Administrative Services Division



Department of Justice – Administrative Services Division

# POP #104 – Essential Costs for Information Technology

Ensuring the ongoing stability of our operating structure.

- Technical adjustment to make permanent the 2017-19 LAB rebaselining amount (\$2.7M), and address the total *agency-wide* technology budget shortfall.
- Primarily Hardware/Software/Security Lifecycle (not project related).
- Maintains the quality, security, and performance of statewide legal and child support work.

**\$4,787,025**

**\$32,716**

**\$93,848**

**Other Funds Limited\***

**Federal Funds**

**General Fund**

*\*DOJ is working with LFO to refine numbers*



# POP #104 – Essential Costs for IT by Category

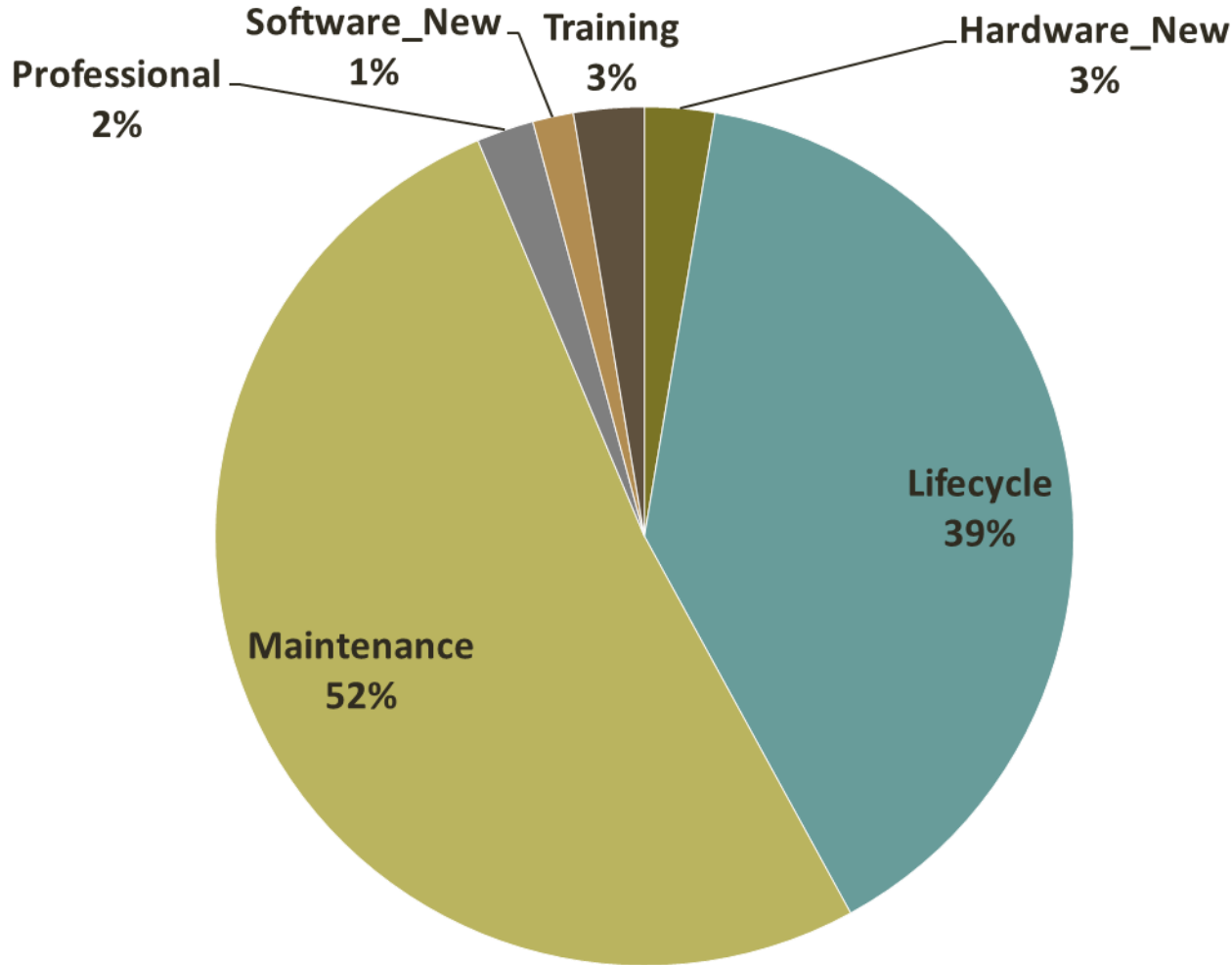

# DOJ Budget - IT Percentage

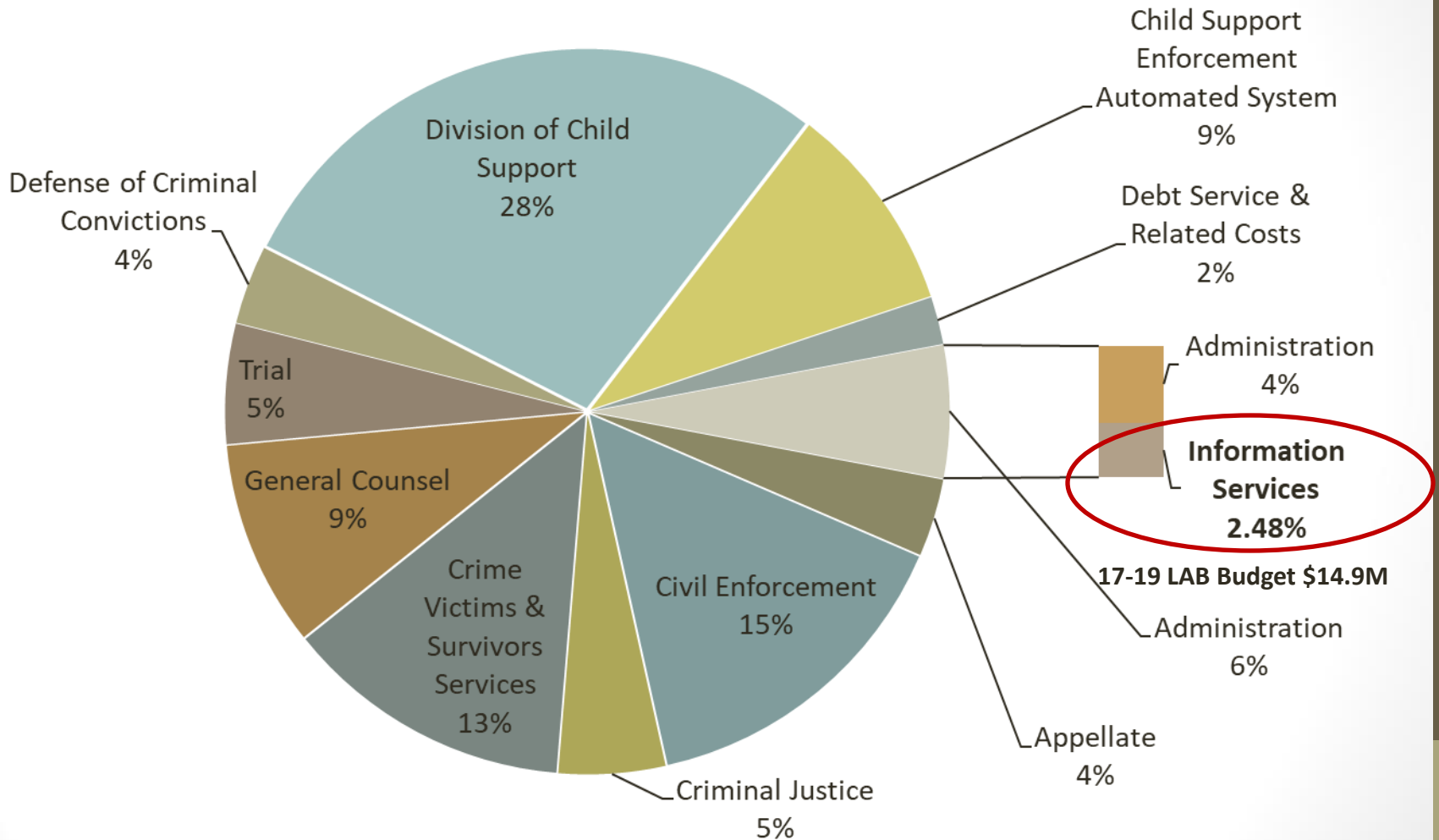



# Customers Supported

★ Total number of DOJ staff supported across the state: 1300

● Total number of District Attorney staff: 170

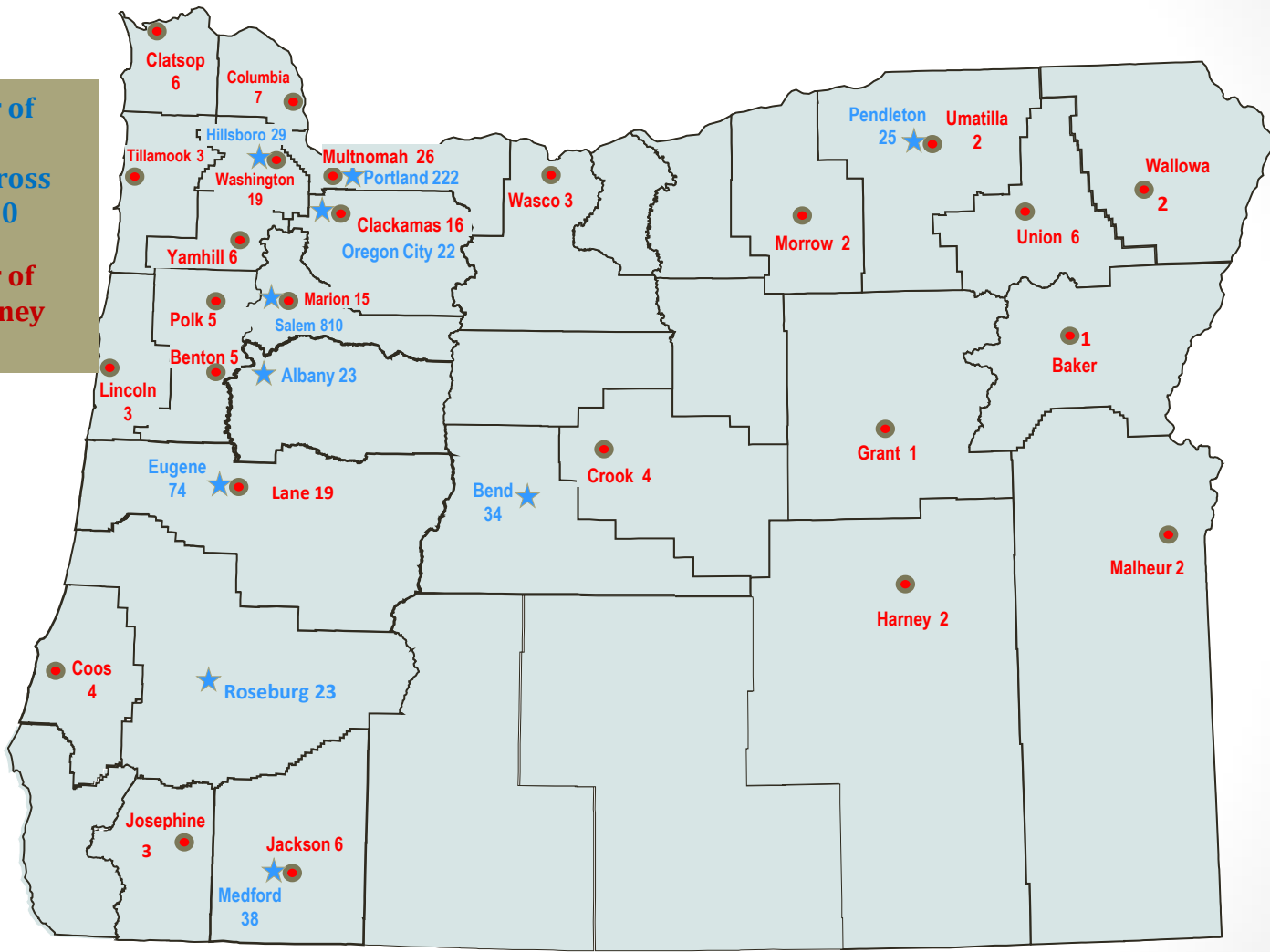

# POP #104 – Essential Costs for IT

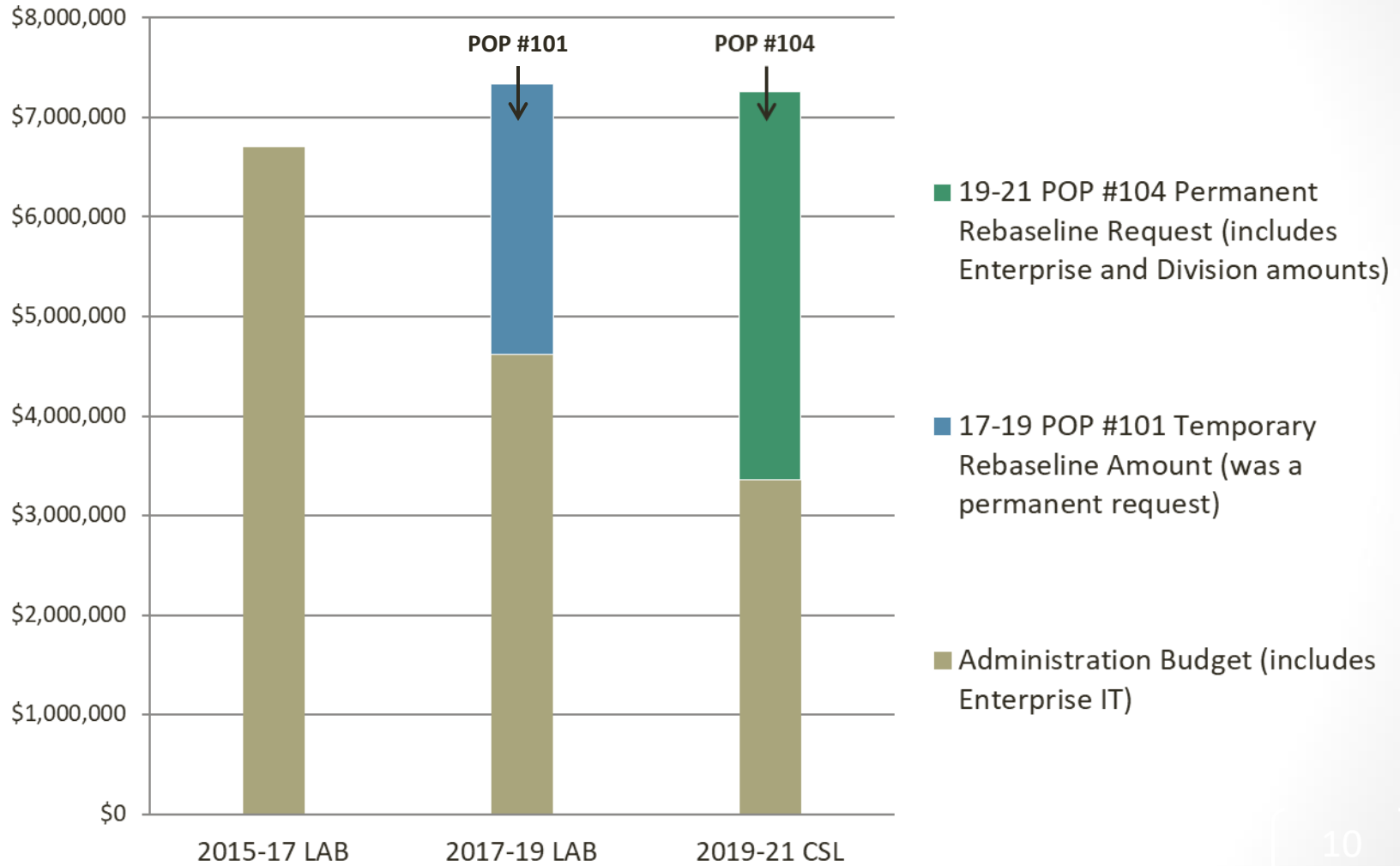

# DOJ IS 5 Year Strategic Information Technology Plan

Enable our agency to prevail in its mission, related litigation, and ensure that child support dollars are distributed to families.

1. Secure and maintain systems and system lifecycle replacement in support of essential services.
2. Develop and implement enhanced support for essential services during and after a disaster.
3. Develop and implement technology standardization for services.
4. Promote innovative and collaborative technology ideas to meet business needs.
5. Enhance and expand information security training and awareness program.



# POP #152 – Legal Tools Expenditure Limitation

Ensuring the ongoing stability of our operating structure.

Support the replacement of DOJ's legal case management system, which upholds the quality, security, and performance of statewide legal and child support work.

- This request has changed since ARB.
- Currently working with OSCIO and LFO.
- Recovered \$569,610 from vendor.
- Requesting limitation of same, \$569,610, to restart the planning phase.
- Will return after planning phase with a full report.

**\$569,610**  
*(recovered funds)*

**Other Funds Limited**

**2 Positions/1.58 FTE**



# POP #158 – Federal Data Security Compliance & Auditing

**Ensuring the ongoing stability of our operating structure.**

Provide funding for a position on the DOJ Information Risk & Compliance Team to manage and track all federal compliance requirements, perform system security audits, and to further enhance and protect our systems and data.

**\$214,654**

**Other Funds Limited**

**1 Position/0.88 FTE**



# POP #150 – Renew HB 2101 Sunshine Committee Staff

## Continue a Legislative Initiative.

Continue the important public records work of the Sunshine Committee as initiated by the 2017 Legislature in HB 2101, which established a 15-member Oregon Sunshine Committee staffed by the Department of Justice. Due to the duration of work anticipated, DOJ requests that the original two .50 FTE temporary (LD) staff positions be made permanent.

**\$302,132**

**General Fund**

**2 Positions/1.00 FTE**



# POP #151 – Defend Oregon Statutes

**Benefits Oregonians by pursuing legal actions in defense of Oregon state statutes and the Oregon Constitution.**

Provide funding to pursue legal actions involving federal government actions that are contrary to Oregon State Laws. These cases involve issues of immigration, funding for the Affordable Care Act, Oregon’s status as a Sanctuary State, and rescission of the Deferred Action for Childhood Arrivals (DACA) program. There could be other actions in the future that Oregon must initiate or join in order to protect Oregonians.

**\$2,000,000**

**General Fund**

**\$1,008,276**

**Other Funds Limited**

**4 Positions/3.52 FTE** (in Trial Division)



# POP #153 – Inclusion and Equity

## Workplace Compliance.

Provide funding for an HR position to coordinate EEOC Title V and VII issues relating to diversity, inclusion, equity, equal opportunity, civil rights, and affirmative action.

**\$227,608**

**Other Funds Limited**

**1 Position/0.88 FTE**





# POP #105 – Grants Management Coordinator Position

## Federal Compliance.

Provide funding for one position to manage approximately 20 federal grants including both direct and pass-through grants from other agencies. Some of the grants have multiple year awards active concurrently.

This request is also in response to an audit recommendation for this position.

**\$206,317**

**Other Funds Limited**

**1 Position/0.88 FTE**





**Oregon Department of Justice**  
Ellen F. Rosenblum, Attorney General

# General Counsel Division



Department of Justice – General Counsel Division

# POP #355 – Two Attorneys in Business Activities

## Responsive High Quality Legal Services.

Respond to increased demand due to increase in volume and complexity of Oregon OSHA cases, increase in hearings arising from appellate court decisions, increase in cases and workload from other client agencies, and loss of experience due to retirements.

**\$604,530**

**Other Funds Limited**

**2 Positions/1.76 FTE**



# POP #354 – Two Attorneys in Tax & Finance

**Responsive High Quality Legal Services.**

Respond to increased demand from Housing & Community Services, Business Oregon and other agencies.

**\$604,530**

**Other Funds Limited**

**2 Positions/1.76 FTE**



# POP #356 – One Attorney in Natural Resources

## Responsive High Quality Legal Services.

Respond to a material increase in demand for legal advice and representation in contested case hearings from the Department of Agriculture, Oregon Water Resources Department, Department of Geology and Mineral Industries, and from the Department of Environmental Quality

**\$302,267**

**Other Funds Limited**

**1 Position/0.88 FTE**



# POP #357 – Paralegal and Legal Secretary Positions

## Responsive High Quality Legal Services.

Add paralegal and legal secretary positions to support the work of new attorney positions, maintaining an effective ratio; facilitate delegation of work to lower billing rate personnel and free attorney time for higher level work

**\$677,724**

**Other Funds Limited**

**4 Positions/3.52 FTE**



# POP #350 – Public Law Conference and Trainings

## Responsive High Quality Legal Services.

Providing quality legal services to state agencies through funding for the biannual Attorney General’s Public Law Conference (PLC) including the creation of three public law manuals, which train and empower agency personnel, expand our reach, and reduce risk.

**\$199,695**

**Other Funds Limited**

**0 Positions/0.00 FTE**



# POP #351 – Four LD Positions to Permanent

## Responsive High Quality Legal Services.

Responding to the ongoing, increased demand for legal services in General Counsel's Government Services Section, Business Transactions Section, Tax & Finance Section, and Health & Human Services Section.

**\$1,610,840**

**Other Funds Limited**

**4 Positions/4.00 FTE**







**Oregon Department of Justice**  
Ellen F. Rosenblum, Attorney General

# **Criminal Justice Division**



Department of Justice – Criminal Justice Division

# POP #251 - Strengthen Criminal Analysis Team

## Enhance Public Safety.

This package would add permanent state-wide analysts to the Criminal Justice Division team to ensure we will be able to provide continued investigative support to state law enforcement agencies and prosecutors.

**\$1,390,685**

**General Fund**

**6 Positions/5.28 FTE**

**(\$212,328)**

**Other Funds Limited**



# POP #251 - Strengthen Criminal Analysis Team

## Front-Line Support to Oregon Police Officers.

- Quick turnaround research.
- Officer Safety.
- Information Sharing.

## Support for Complex Criminal Investigations.

- Homicide.
- Human Trafficking.
- Elder Abuse.
- Financial Crime.



# POP #251 - Strengthen Criminal Analysis Team

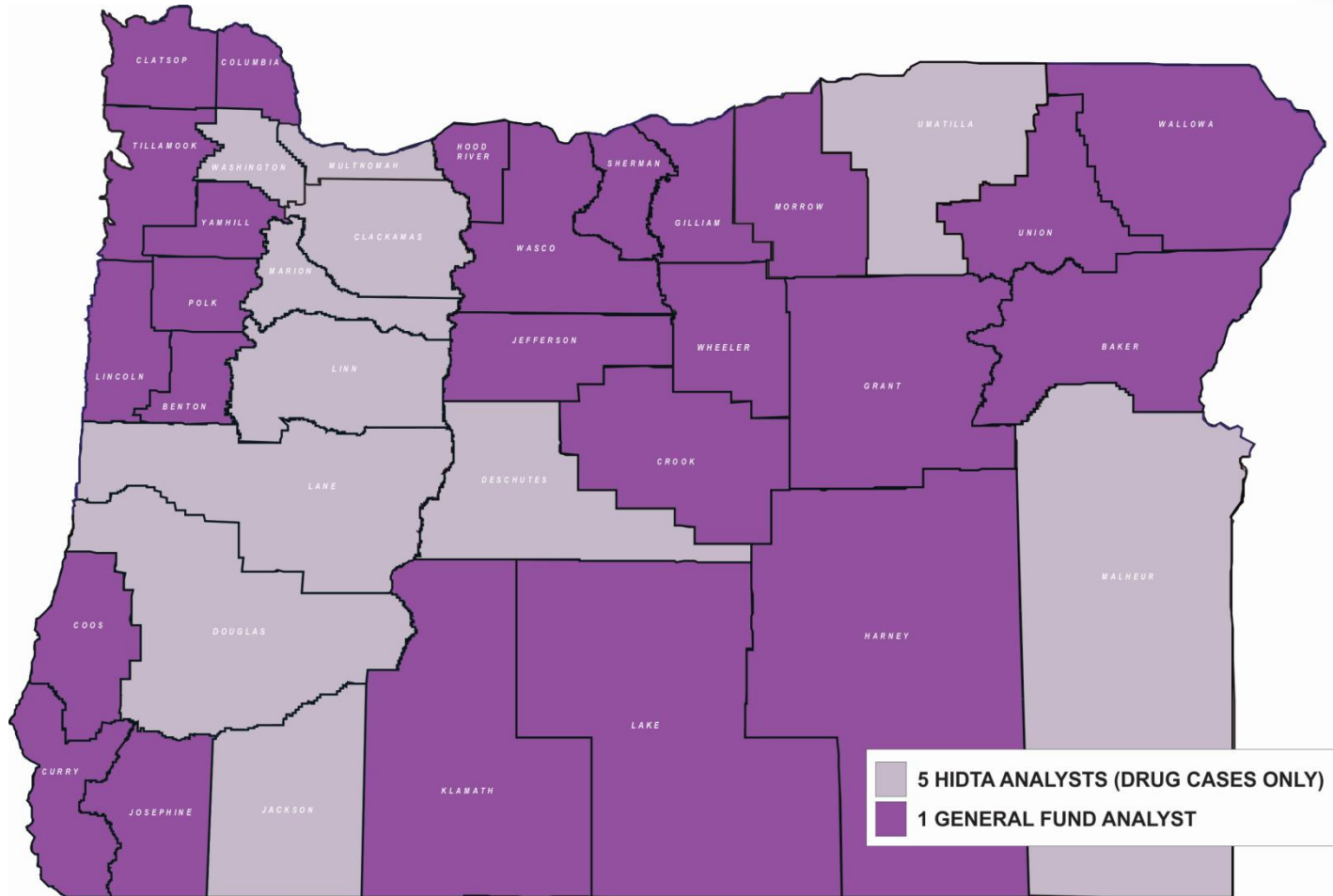

# POP #256 - Criminal Information Services Section Manager

**Enhance Public Safety.**

Adds a manager to act as a direct-line supervisor for the analysts in the Criminal Justice Division. This position was previously grant funded.

**\$258,517**

**General Fund**

**1 Position/0.88 FTE**



# POP #252 - Change Criminal Justice Funding Source

## Increase Transparency of Budgeted Funding.

Currently, 17 positions in the Criminal Justice Division are paid with General Fund and 22 positions are paid through the Legal Fund. Shifting primarily to a single funding source is expected to increase transparency in budgeting for the Division.

<b>\$2,004,790</b>	<b>General Fund</b>	<b>0 Positions/0.00 FTE</b>
<b>(\$9,120,490)</b>	<b>Other Funds Limited</b>	





**Oregon Department of Justice**  
Ellen F. Rosenblum, Attorney General

# Civil Enforcement Division



Department of Justice – Civil Enforcement Division

# NEW Package – Consumer Privacy

## Protecting Oregon Citizens.

Position authority and expenditure limitation to handle increased workload in the areas of data privacy, data security, and high tech fraud. Authorizes additional technical and legal staff to handle large-scale, complex matters affecting large numbers of Oregon consumers.

**\$922,340**

**Protection & Education Funds**

**3 Positions/2.64 FTE**





# POP #203 – Tobacco Criminal Investigator

## Protecting Oregon Citizens.

Position authority and funding for a Criminal Investigator to investigate possible criminal activity relating to the sale and distribution of cigarettes in Oregon. Position will support enforcement efforts under the Tobacco Master Settlement Agreement (MSA).

**\$296,710**

**Tobacco MSA Funds**

**1 Position/0.88 FTE**



# POP #202 – Increase in Child Support Legal Caseload

## Oregon's Families.

Position authority and budget limitation due to increased workload related to four counties transferring the private child support caseload to the Department of Justice.

### Civil Enforcement Division:

<b>\$2,218,614</b>	<b>Other Funds Limited</b>	<b>8 Positions/7.02 FTE</b>
--------------------	----------------------------	-----------------------------

### Division of Child Support:

<b>\$2,065,085</b>	<b>Federal Funds</b>	<b>0 Positions/0.00 FTE</b>
--------------------	----------------------	-----------------------------

<b>\$1,032,543</b>	<b>General Fund</b>	<b>0 Positions/0.00 FTE</b>
--------------------	---------------------	-----------------------------



# POP #201 – Child Advocacy Multnomah County

## Oregon’s Children – Full Juvenile Dependency Legal Representation.

Position authority and budget limitation for Child Advocacy work in Multnomah County. This is necessary to complete the implementation of the third phase of full juvenile dependency legal representation of DHS Child Welfare caseworkers.

**\$9,862,822**

**Other Funds Limited**

**34 Positions/32.5 FTE**



# POP #201 – Child Advocacy Multnomah County

	Original Request		Adjustment		Total Request	
	Positions	FTE	Positions	FTE	Positions	FTE
Attorney in Charge	0	0.00	1	1.00	1	1.00
Assistant Attorney General	7	7.00	0	0.00	7	7.00
Senior Assistant Attorney General	5	5.00	3	3.00	8	8.00
Legal Secretary	5	5.00	3	2.50	8	7.50
Paralegal	5	5.00	2	2.00	7	7.00
Office Specialist 1	2	1.50	1	0.50	3	2.00
Total Position/FTE	24	23.50	10	9.00	34	32.50
Total Cost	\$7,005,535		\$2,857,287		\$9,862,822	



# POP #200 – Child Advocacy Budget & Position Realignment

## Oregon's Children – Full Juvenile Dependency Legal Representation.

Refined and adjusted position authority and budget limitation for the full juvenile dependency legal representation of DHS Child Welfare caseworkers . This package is necessary to fully implement court representation of DHS caseworkers across the state.

**\$6,826,586**

**Other Funds Limited**

**20 Positions/16.81 FTE**



# POP #200 – Child Advocacy Budget & Position Realignment

		Resolve Double Fills	Eugene Temp Employees to Permanent	Child Advocacy Expansion Position True Up	Manager Position True Up	Additional Staff for Base Program	Temp Limitation	Total
Original Request	Positions	4	2	0	0	0	0	6
	FTE	3.00	2.00	0.00	0.00	0.00	0.00	5.00
	Total Cost	\$1,182,361	\$335,097	\$1,872,430	\$16,899	\$0	\$144,688	\$3,551,475
Adjustment	Positions	0	0	0	0	14	0	14
	FTE	0.00	0.00	0.00	0.00	11.83	0.00	11.83
	Total Cost	\$0	\$0	\$0	\$0	\$3,275,111	\$0	\$3,275,111
Total Current Request	Positions	4	2	0	0	14	0	20
	FTE	3.00	2.00	0.00	0.00	11.83	0.00	16.83
	Total Cost	\$1,182,361	\$335,097	\$1,872,430	\$16,899	\$3,275,111	\$144,688	\$6,826,586





**Oregon Department of Justice**  
Ellen F. Rosenblum, Attorney General

# **Trial Division**



# POP #400 – Transportation Package Condemnation Work

Assist ODOT to acquire property when necessary to maintain, improve and add to the state's highway infrastructure.

ODOT anticipates our average caseload will increase 200% over the next 1-3 years (from 50 cases/year to 150 cases/year).

**\$900,872**      **Other Funds Limited**      **3 Positions/3.14 FTE**





# NEW Package – Water Resources Department Legal Services

Defending Oregon Water Resources Department (OWRD) decisions related to regulation of water rights.

- Regulation of junior water rights to meet the rights of senior water right holders.
- Regulation of water users using water without a water right.
- Regulation of use that is inconsistent with the conditions and limitations contained in a water right.

**\$414,149**

**Other Funds Limited**

**3 Positions/2.20 FTE**

\*See accompanying POP #356 in General Counsel for additional related position.



# NEW PKG – Defense of Criminal Convictions/ Trial Division Mandated Caseload Revision

Preserving convictions and sentences obtained by the state’s prosecutors.

Main factors driving increased workload:

- Increased scrutiny of Post Conviction Relief (PCR) claims by the Oregon trial and appellate courts.
- Increase in the number of PCR claims and length of petitions.
- Increase in the use of expert witnesses.
- Increase in length of trial memoranda.
- Average hours worked per PCR case has increased from 43.79 to 57.04 in the last 18 months.

<b>\$769,870</b>	<b>Other Funds Limited in Trial</b>	<b>2 Positions/2.50 FTE</b>
<b>\$1,652,775</b>	<b>General Fund in DCC</b>	





**Oregon Department of Justice**  
Ellen F. Rosenblum, Attorney General

# Division of Child Support



Department of Justice – Division of Child Support

**What we're about:**

**Supporting parents  
to  
support children.**



# Oregon's Federal Title IV-D Program

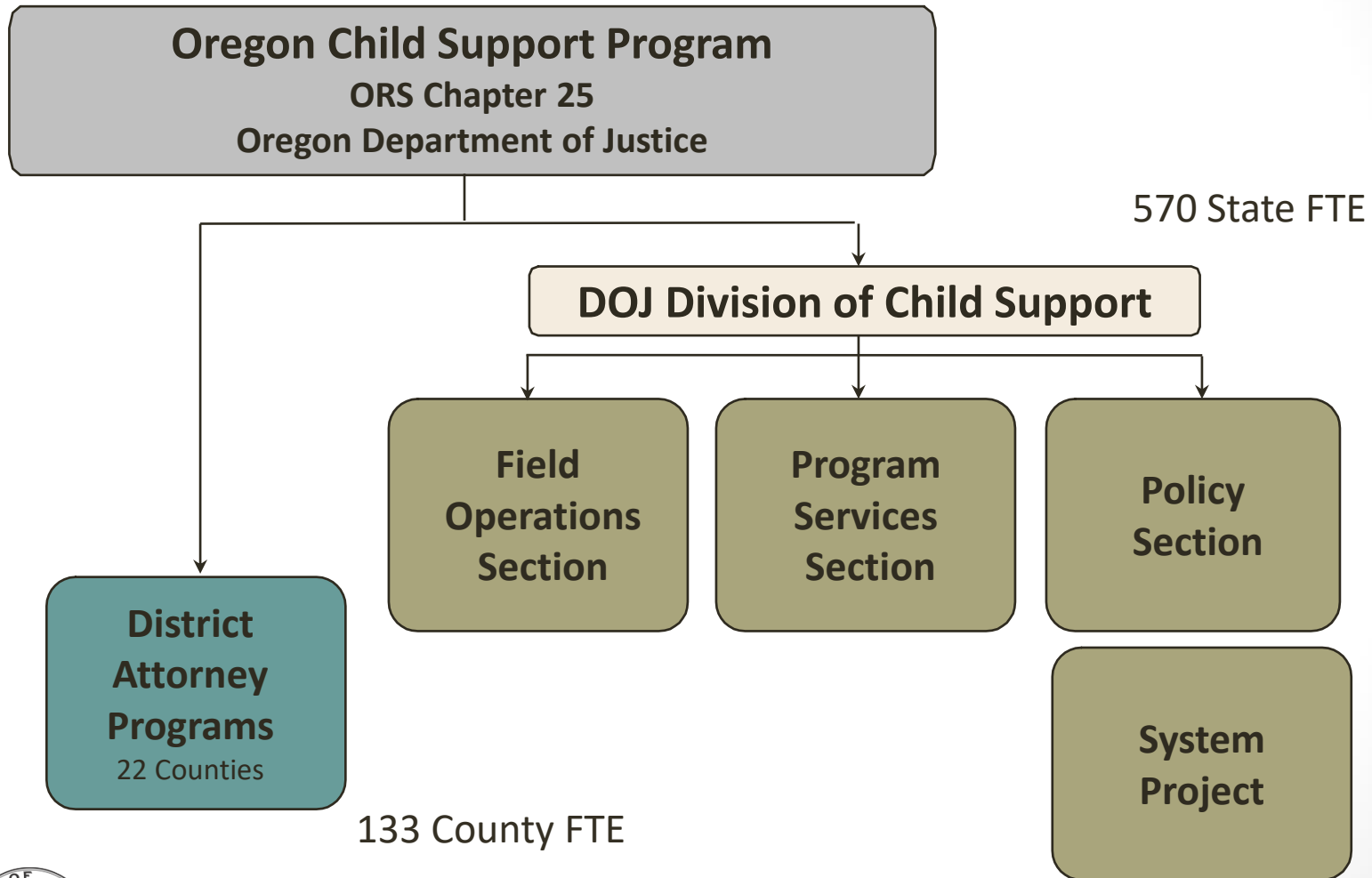

# Presentation Overview

## Policy Option Packages

### Basic operations

- #450 – Revenue reduction restoration
- #452 – Operations & maintenance for Origin

### System project

- #451 – System hosting for Origin
- #475 – System project funding/close-out

### Legal costs for child support (Civil Enforcement Division)

- #202 – AAG costs to support child support program



# POP #450 – Revenue Restoration

## Diminishing Funding Stream – Other Funds

### Ongoing loss of recoveries resulted in 070 – Revenue Reduction

DOJ Division of Child Support collects TANF recoveries as revenue to help fund operations expenses (Other Funds)

But the nature of child support programs – and their funding – has been changing over several biennia, and will continue to do so

- TANF caseloads diminishing both nationally and in Oregon
- State-assigned TANF recoveries continue to decline due to law changes related to TANF
- Increase in percentage of collections going to Oregon families due to evidence-based changes in state law and policy

### Reduction in Other Funds operating revenue results in related loss of matching federal funding.

- \$6.2 million reduction in recoveries + \$11.6 million related reduction in federal match = **total reduction of \$17.8 million**



# POP #450 – Revenue Restoration

This request substitutes General Fund for the lack of Other Funds revenues required for the state share (1/3) of the operating budget

**\$6.2 M GF enables \$11.6 FF match = \$17.8 M in total funding**

**91.44 FTE (92 positions)**

**16% of the Division's personnel**

- Impacts to funding and performance also impact 22 DA offices
- Greatest impacts to Program federal performance measures 12-18 months following staffing reduction
- Failing federal performance requirements results in:
  - Penalties and reduced incentive funds to Child Support Program
  - **Direct reduction in the state TANF grant**





# POP #450 – Revenue Restoration

	<u>Agency Requested Budget</u>	<u>Adjusted Request to LFO</u>
Restoration of Revenue Reduction	\$6.20 M GF	same
	<u>\$11.57 M</u> FF	
<b>Total</b>	<b>\$17.77 M</b>	

**Maintains current service level: 91.44 FTE (92 positions)**



# POP #452 – Origin Support Package

## Origin Operations & Maintenance

- Moving from project to operationalization
- Repurpose and enhance current (and prior) biennia system project FTE to operations
  - Same staff embedded with implementation contractor (Deloitte) throughout the design, development, implementation of Origin
- Leverage current management structure
  - No new management positions
- Meets Origin operational system support needs in house without augmenting with contracted system support services
- Two categories of positions: business & technology



# POP #452 – Origin Support Package

## Origin Operations & Maintenance – Technology Team –

Repurposing system project FTE/positions for operations

- Information System Specialists
  - **Developers**
    - Support Presentation tier
    - Web-based user interface applications
  - **Middleware Administrators**
    - Support Application/Communication tier – Java, IBM COTS
    - Security Operations Administrators
  - **Database Administrators**
    - Support Database tier
    - Relational databases, data dictionaries, data warehouse



# POP #452 – Origin Support Package

## Current State: Legacy + System Project Technology Teams

### Legacy FTE

Child Support Technology Services

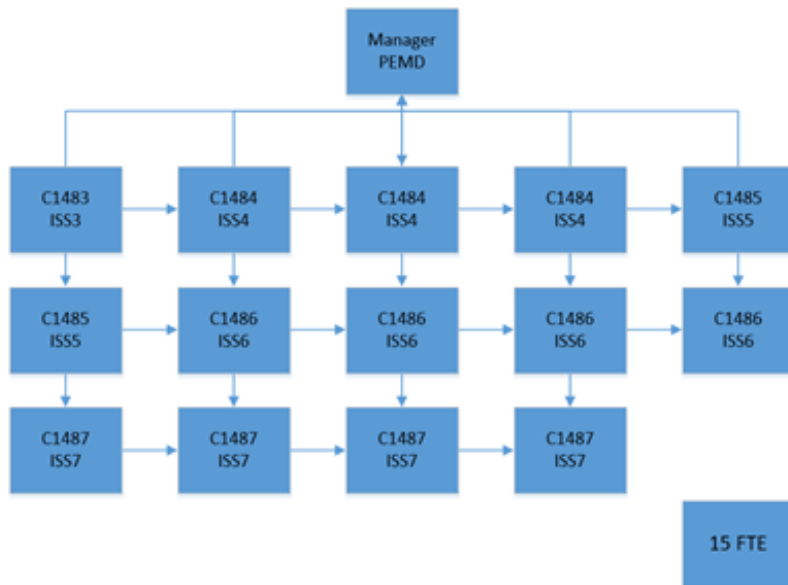

### System Project FTE

Origin Project Technology Positions

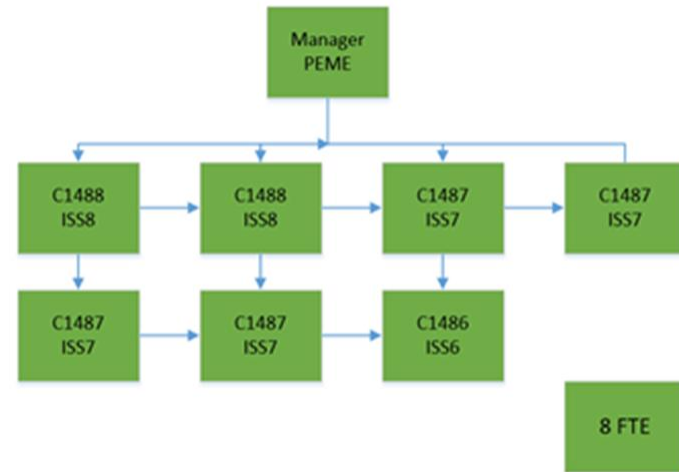

plus 78 Deloitte staff  
(200 total for project)



# POP #452 – Origin Support Package

## Future State: Origin Operations & Maintenance Technology Team



# POP #452 – Origin Support Package

## Origin Operations & Maintenance – Business Team –

Repurposing system project FTE/positions for operations

- Operations and Policy Analyst (OPA) positions – Business Analysts
  - Maintain the current level of system support for Origin
  - Provide Help Desk support
  - Provide regulatory compliance and role-based system access coordination
  - Manage system change projects (e.g., other agency system upgrades, business improvements and activities, state and federal legislative changes, security or other technological advances)
- Project Manager
  - Project management principles and execution employed throughout operations and business



# POP #452 – Origin Support Package

## Future State: Origin Operations & Maintenance Business Team

- Current FTE
- Current FTE (reclassification)
- System Project FTE (repurposed to O&M)

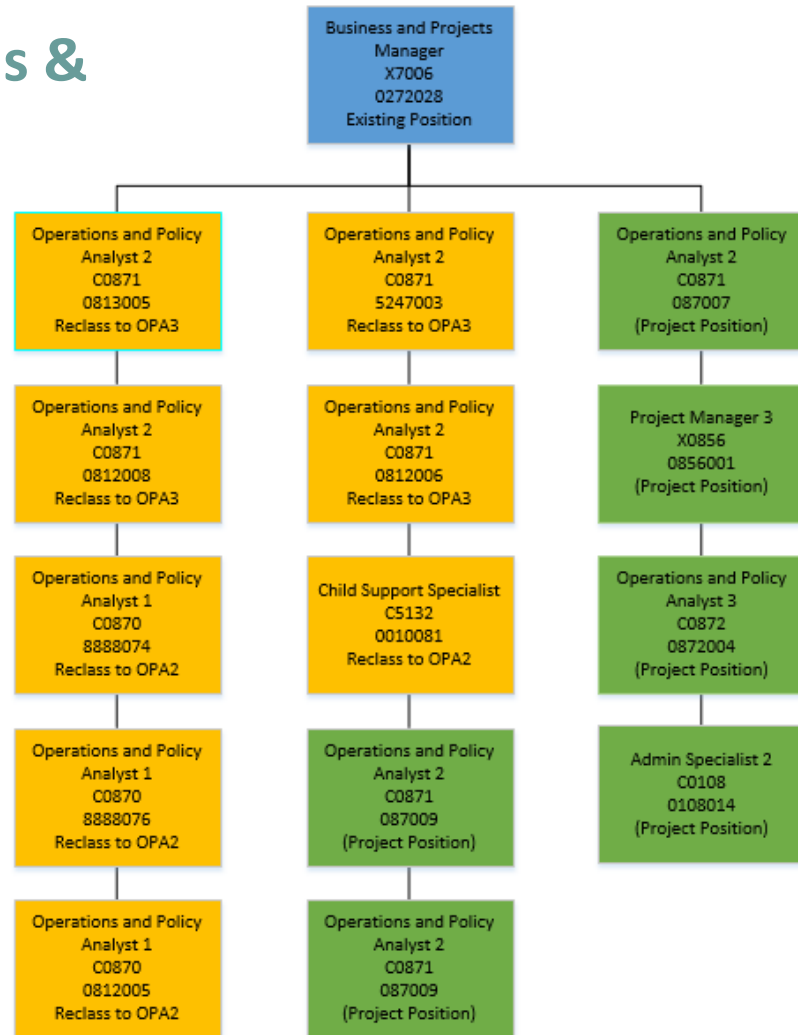

# POP #452 – Origin Support Package

## Origin Operations & Maintenance

Without this package, vendor support would be necessary to operate Origin to maintain functionality of the Oregon Child Support Program. Estimated cost for vendor (Deloitte): **\$13.4 million** in addition to the contracted costs for finishing the system project.

Period	Estimated Cost	Description of Services
Jun 2019 – May 2020	\$ 5,076,825	Current plan: Deloitte provides primary O&M support and the agency provides secondary support. The cost is for Deloitte to assume the additional scope of O&M instead.
Jun 2020 – May 2021	\$ 7,382,302	Current plan: Deloitte provides secondary O&M support and the agency provides primary support. The cost is for Deloitte to assume the additional scope of O&M instead.
June 2021	\$ 976,323	Current plan: The agency to completely take over O&M support, without Deloitte assistance. The cost is for Deloitte to assume full O&M support instead.
	\$ 13,435,450	2019-2021 Deloitte System Support Cost Estimate





# POP #452 – Origin Support Package

	<u>Agency Requested Budget</u>	<u>Adjusted Request for LAB</u>
<b>Origin Operations &amp; Maintenance</b>		
Positions	25	21
FTE	16.75	13.23
	\$1.43 M GF	\$1.13 M GF
	<u>\$2.70 M</u> FF	<u>\$2.19 M</u> FF
<b>Total</b>	<b>\$4.12 M</b>	<b>\$3.32 M</b>



# POP #475 – System Project

## New Child Support System – Origin

**All states must maintain a child support automated system that meets federal certification requirements.**

- Oregon’s former system (CSEAS) was one of the oldest systems in the nation, using components and databases from the 1970s
- The Program has worked with its federal oversight office on a multi-year, prescribed process to replace its certified system
- POP 475 allows the Program to complete the last phases of the project: federal certification, post-implementation technical knowledge transfer, and operationalization
- This package also includes debt service for the last series of bonds sold in February 2019



# POP #475 – System Project

## Legislative Timeline

Feasibility Study Report – Nov 2011 to Oct 2012

Business Process Re-engineering – Dec 2012 to Dec 2013

Planning Approval – 2013 Legislative Session

Stage Gate 3 & Readiness Assessment Approval – 2016 Legislative Session

Continuation of Implementation Project – 2016 through 2017-19 Biennium

Federal Certification, Stage Gate 4 & Project Close-out – 2019-21 Biennium

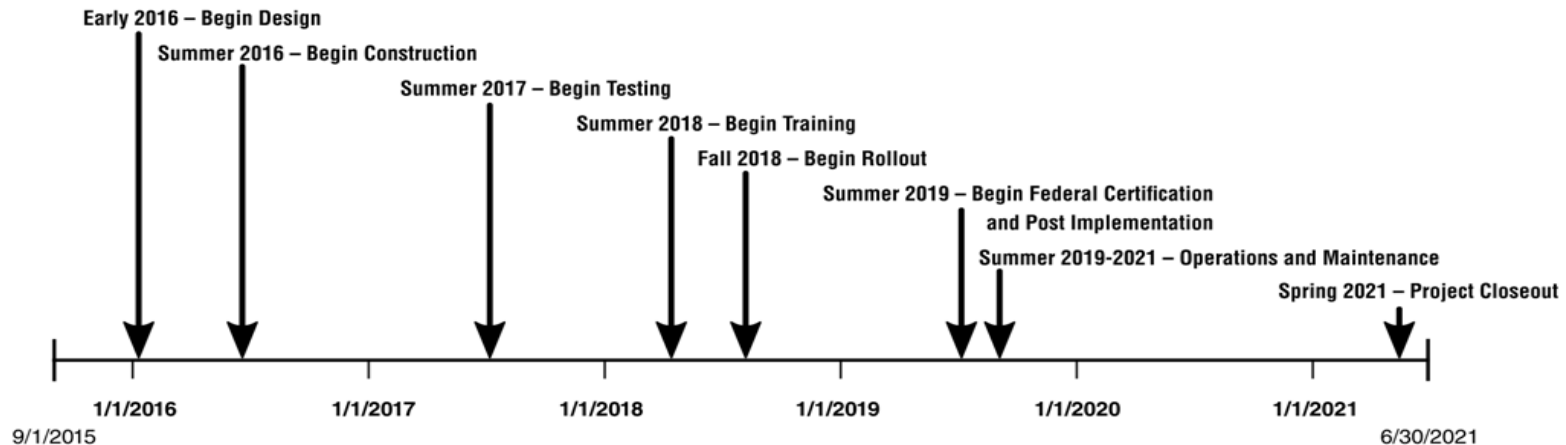

# POP #475 – System Project

	<u>Agency Requested Budget</u>	<u>Adjusted Request for LAB</u>
<b>System Project Close- Out &amp; Debt Service</b>	\$2.91 M GF	\$2.13 M GF
	\$2.74 M OF	\$3.69 M OF
	<u>\$10.97 M</u> FF	<u>\$11.31 M</u> FF
<b>Project Budget Subtotal</b>	<b>\$16.62 M</b>	<b>\$17.13 M</b>
<b>Debt Service Subtotal</b>	<b>\$0.46 M GF</b>	<b>\$1.48 M GF</b>
<b>Total</b>	<b>\$17.08 M</b>	<b>\$18.61 M</b>



# Other Policy Option Packages

	<u>Agency Requested Budget</u>	<u>Adjusted Request for LAB</u>
<b>POP #451</b>		
<b>System Hosting</b>	\$1.44 M GF	same
	<u>\$2.80 M</u> FF	
<b>Total</b>	<b>\$4.24 M</b>	

- Origin is currently hosted with Atmosera, a vendor under contract with Oregon’s Enterprise Technology Services to provide overflow services to state agencies.
- Although eventual migration to the State Data Center is planned, it does not have the capacity and technology to support this system.



# Other Policy Option Packages

	<u>Agency Requested Budget</u>	<u>Adjusted Request for LAB</u>
<b>POP #202</b>		
Child Support	\$0.72 M GF	\$1.03 M GF
Legal Caseload	<u>\$1.39 M</u> FF	<u>\$2.06 M</u> FF
<b>Total</b>	<b>\$2.11 M</b>	<b>\$3.09 M</b>

- Increase in number of counties in which DOJ Division of Child Support handles the entire caseload
  - Klamath, Josephine, Benton, Wasco county programs returned to the state
  - Non-assistance caseload typically has more legal actions in circuit court
- Increase in civil contempt efforts, resulting in significantly larger collections for families





**Oregon Department of Justice**  
Ellen F. Rosenblum, Attorney General

# **Budget Requests that do not impact the General Fund**



Department of Justice – No General Fund Impact

# POP #300 – Victims of Crime Act Budget

## Supporting Crime Victims and Survivors.

Since 2016, funding for the Victims of Crime Act (VOCA) has continued to increase. The VOCA Assistance award is sub-granted through the Division to non-profit and prosecutor-based victim service providers as well as child abuse intervention centers.

**\$58,074,323**

**Federal Funds Limited**

**3 Positions/2.64 FTE**





# POP #250 Ongoing Grants (UASI & SHSP)

## Investigating Complex Crimes.

- Urban Area Security Initiative (UASI) grant is designed to assist high-threatened and high density urban areas.
- State Homeland Security Program (SHSP) grant assists state, tribal and local preparedness gap activities.
- Both federally funded through the Oregon Office of Emergency Management/Military.

**\$569,430**

**Other Funds Limited**

**2 Positions/2.00 FTE**



# POP #453 - Federal Fee Change

## Implementing a Federal Law change.

- The federal Bipartisan Budget Act of 2018 increased the annual collection fee for Child Support Programs from \$25 to \$35.
- The law also revises from \$500 to \$550 the amount that the State must collect and disburse to the family before imposing the collection fee each year.

**\$69,800**

**Other Funds Limited**

**0 Positions/0.00 FTE**





**Oregon Department of Justice**  
Ellen F. Rosenblum, Attorney General

# Reconciliation & Technical Adjustments



# Position Adjustments

Changes to budgeted positions to realign them with actual business needs and resolve work out of class and other budgetary matters.

- Adjusts 9 positions in the Administration Division.
- Adjusts 4 positions in the Trial Division.
- Adjusts 5 positions in the Civil Enforcement Division.
- Moves 3 positions from the Civil Enforcement Division to the Administration Division.
- Moves 4 positions in the Civil Enforcement Division across programs.
- Moves 1 position in the Criminal Justice Division across programs and changes funding split.

**\$46,336 General Fund**

**\$31,212 Other Funds Limited**

**\$12,384 Federal Funds Limited**

**\$89,932 Total Funds**



# POP #100 – Reconcile Intra-Agency Charges

- Administration Division expenses are funded by assessing the other DOJ divisions a share of the costs.
- Allocations are determined using a model reviewed and approved by the federal government.
- DOJ budget does not match the federally approved charges.
- Without this funding, other budgets must be used to fill this gap.

\$2,384,957	General Fund	0 Positions/0.00 FTE
\$7,150,711	Other Funds Limited	0 Positions/0.00 FTE
\$1,802,489	Federal Funds Limited	0 Positions/0.00 FTE



# POP #102 – Reconcile Attorney Position Classifications

This policy package is to reconcile actual attorney salaries with budgeted attorney salaries which have become out of sync over time. New attorney positions are budgeted at a default entry level and do not account for the salary associated with hiring an experienced attorney.

## Divisions Affected:

- Trial
- Appellate
- General Counsel
- Civil Enforcement
- AG Office

**\$3,469,381**

**Other Funds Limited**

**0 Positions/0.00 FTE**

**( 70 )**





**Oregon Department of Justice**  
Ellen F. Rosenblum, Attorney General

# Legal Fund



# DOJ's statutory billing authority

- **180.160 Charges for services to public agencies; rules.**
  - Provides that DOJ may charge agencies and other public bodies for rendering legal assistance.
- **180.170 Billing for services to public agencies.**
  - Provides that DOJ shall estimate biennial expenses in advance and invoice agencies and other public bodies for their share of these expenses. Provides for adjusting future invoices for prior differences between actual and estimated expenses.
- **The hourly billing rate is not set in statute. It is developed in conjunction with the development of the biennial budget.**
  - The rate is not final until the end-of-session omnibus budget bill.





# What is the Legal Fund?

The Legal Fund is an internal service fund which records the revenues and expenses for providing Legal Services to state government.

Examples of Other Internal Service Funds: Motor Pool, Copy Machines  
– each with a user fee.



# Legal Fund Budget Model:

- Other Funds expenditure limitation to hire employees and pay operating costs.
- The legal rate billed to client agencies has to be adequate to fund:
  - The attorney
  - Contribute to division operating costs for supplies, services, technology, capital items and costs charged to divisions for rent, payroll, accounting, human resources, etc.
  - Ideally, billed revenue should equal actual expenses.



# How does the billing process work?

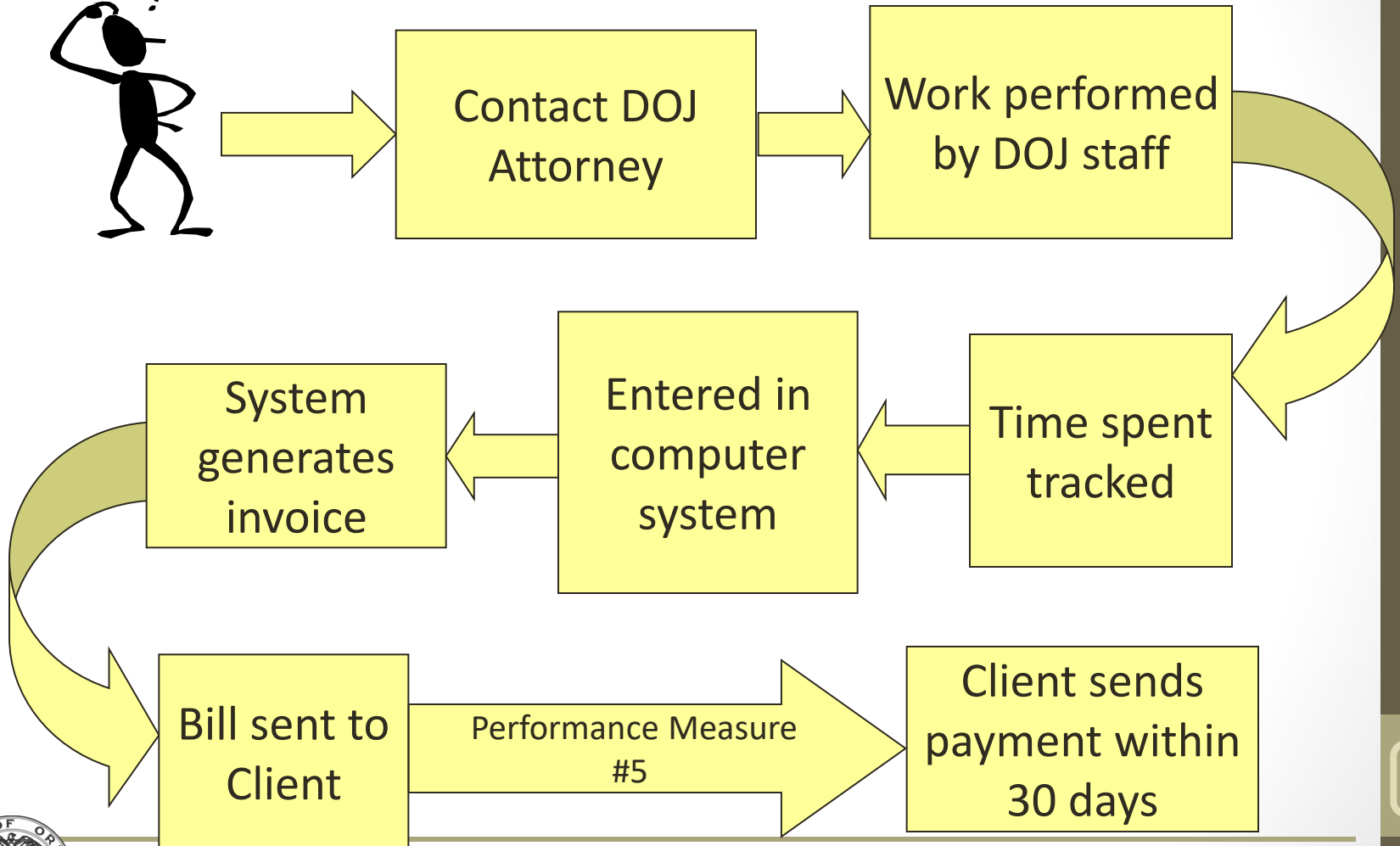
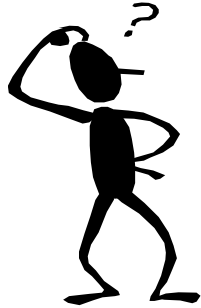

# How does the Department of Justice determine the Legal Rate?



# Legal Rate – Two Components

**Direct Cost of the Hours of Work**

**Plus**

**Operating Costs and Assessments  
for Agency & State Overhead \***

\* - Overhead includes non-billable hours, division operating costs, administrative assessments the department receives for technology, telecommunications, rent, insurance, accounting and human resources.



# Calculation of the Legal Rate

$$\text{Rate}^* = \frac{\text{Total projected biennial legal service costs}}{\text{Projected number of biennial billable hours}}$$

\* - Rate is actually assigned in the end-of-session omnibus budget bill.



# Legal Rate Parallels the State Budget Process

- **Agency Request Budget** – Legal Rate is an estimate of the ARB with all budgetary requests made by the Department of Justice. **\$223 / Hour**
- **Governor’s Budget** – Legal Rate recalculated to represent Current Service Level plus adopted Policy Option Packages and other components of Governor’s Budget. **\$208 / Hour**
- **Legislatively Adopted Budget** – Legal Rate recalculated for each legislative budget decision affecting Department of Justice. **\$??? / Hour**





**Oregon Department of Justice**  
Ellen F. Rosenblum, Attorney General

# Key Performance Measures





# Performance Measures

- 1 % of legal cases in which the state's position is upheld.
- 2 % of appropriate litigation resolved through settlement.
- 3 Amount of monies recovered for the state divided by the cost of recovery.
- 4 Average time from receipt of contracting document to first substantive response to agency.
- 5 Percent of legal billing receivables collected within 30 days.
- 6 % of timely and complete charities' reports submitted relative to total charities registered.
- 7 % of customers rating agency's customer service as "good" or "excellent"; overall customer service.
- 8 % of Criminal Justice Division cases resolved successfully.
- 9 % of crime victims compensation orders issued within 90 days of receipt.
- 10 % of support collected by the Child Support Program (CSP), which is distributed to families.
- 11 % of current child support collected relative to total child support owed.
- 12 % of CSP cases paying towards arrears relative to total CSP cases with arrears due.
- 13 % of CSP cases with support orders relative to total CSP cases.
- 14 % of adult victims leaving Domestic Violence shelters with a safety plan after a stay of five days or more.
- 15 % of sexual assault exams conducted by specially trained Sexual Assault Nurse Examiners (SANE).
- 16 % of Defense of Criminal Convictions (DCC) cases briefed within 210 days.



# Performance Measures

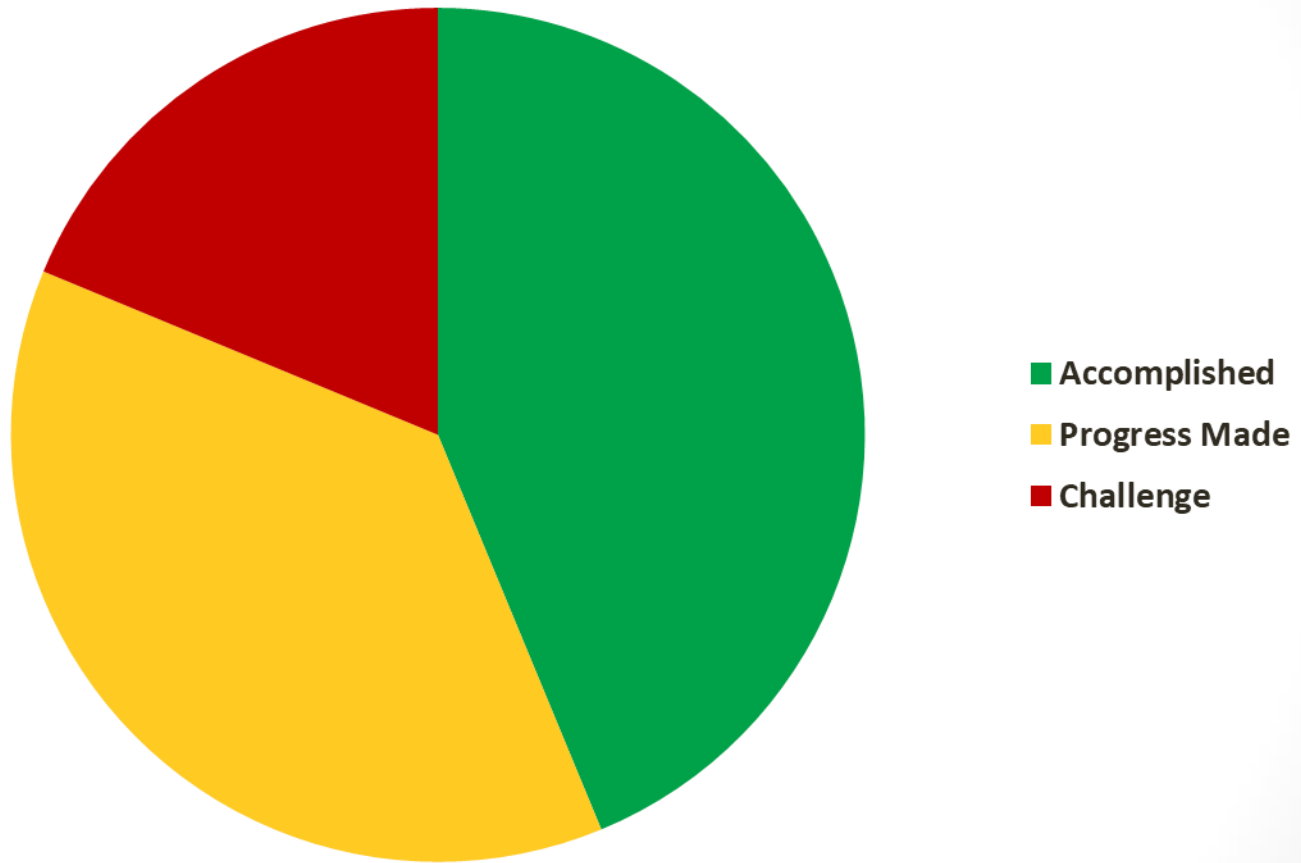

# Performance Measures

## Key Performance Indicator – DOJ Service Rating by Agencies

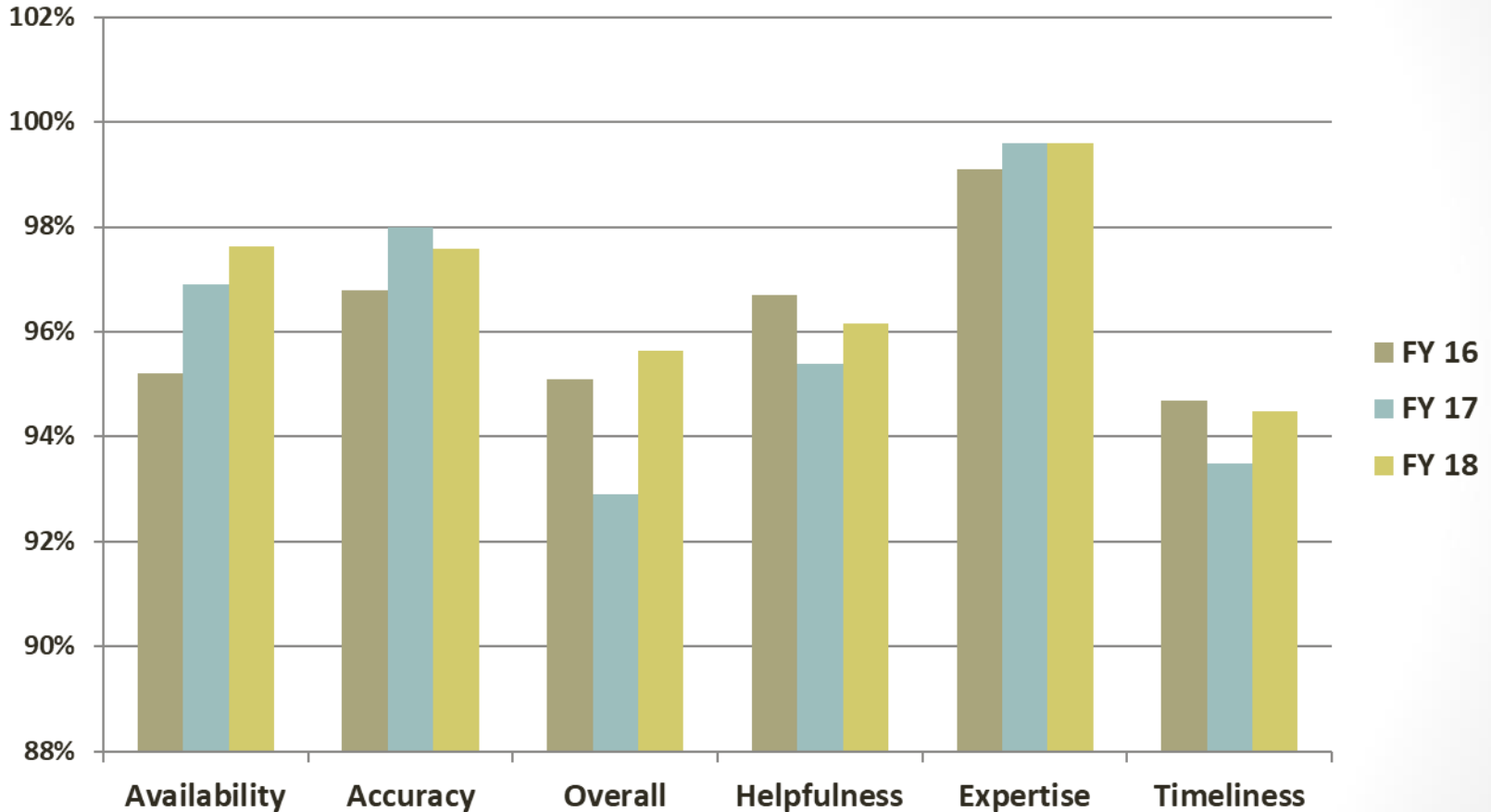

# Questions?

